

BUILD-A-RAIL GUARD RAILS

Heavy-duty design
protects against
impact damage

Customizable for
different lengths
and heights

Easily assembled
and disassembled

BUILD-A-RAIL

Build-A-Rail Guard Rails are heavy duty, customizable and easily assembled to protect property from damage due to forklift impact.

Build rail systems one, two or three rails high by just stacking rail units one on top of the other. Available in 4 foot, 6 foot, 8 foot and 10 foot lengths. Can be coupled together to make runs as long as you want. Make 90 degree corners by connecting two rail systems together with a corner coupler.

Features and Benefits

- Barriers are rated to withstand an impact of 10,000 lbs. at 4 MPH and will keep valuable equipment safe from forklift traffic.
- Rail sections are constructed of sturdy $\frac{5}{32}$ " wall 4" x 4" steel tube
- Base units are constructed of $\frac{5}{32}$ " wall 4" x 4" steel tube welded to $\frac{5}{8}$ " thick 10" x 10" base plates
- Highly visible, yellow powder coat painted steel units provide a visible, durable, and attractive finish
- Durable and attractive black plastic end caps close ends and tops giving a finished look
- Stackable and side-by-side joinable units provide flexibility in guard rail system design
- Straight sections and 90 degree turns are easily accomplished using straight and corner couplers
- Build-A-Rail sections are installed correctly by following easy-to-use instructions

Areas of Installation

Build-A-Rail Guard Rails are designed to protect: in plant offices, production equipment, walkways, end-of-rack aisles, and more!

Guarantee and Warranty

Personal and professional customer service is offered on all Handle-It® Build-A-Rails. Our Build-A-Rail carries a two-year limited warranty on all materials and workmanship.

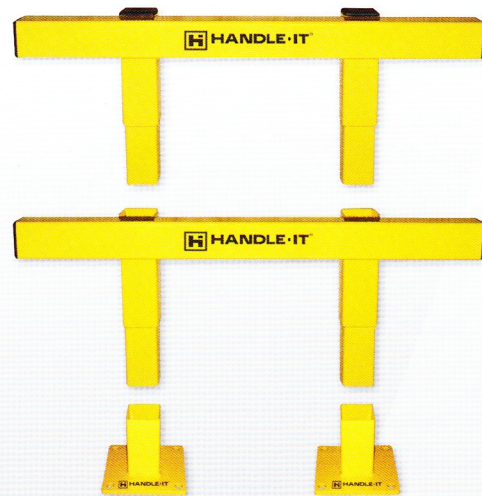

Stackable units

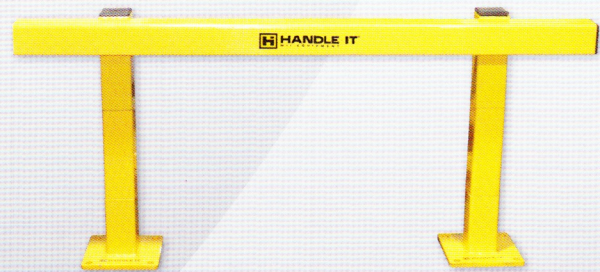

Single rail with extension



Side-by-side joinable units

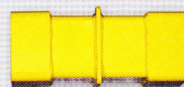

Collar connector



Corner collar connector



Base units

BUILD-A-RAIL DIMENSIONS

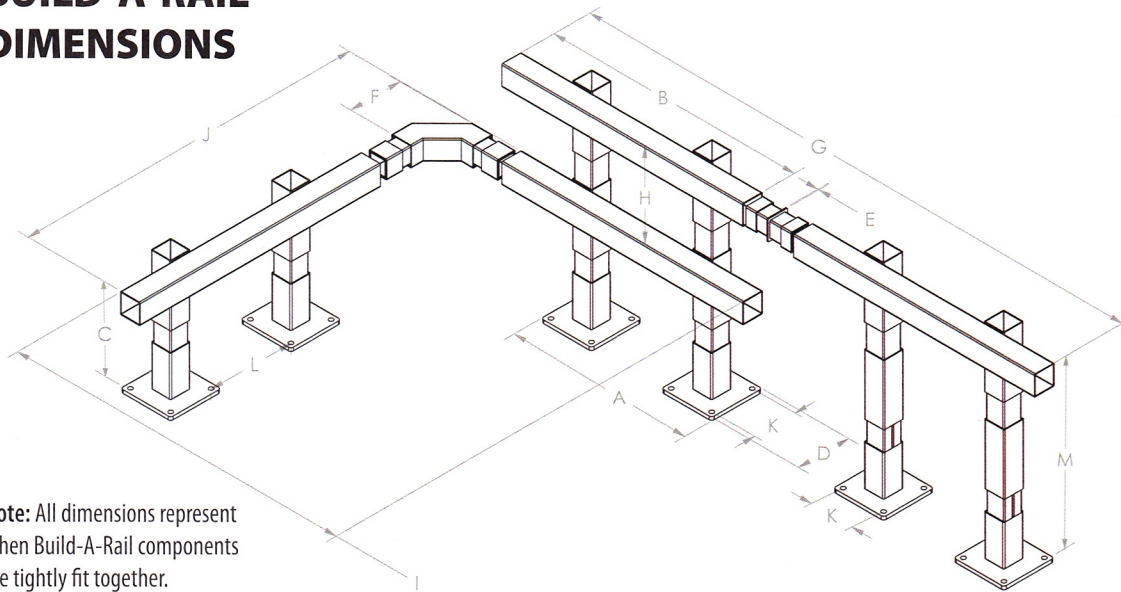

Note: All dimensions represent when Build-A-Rail components are tightly fit together.

- 1 Measure overall length of area that is to be protected.
- 2 Is there a protruding object or other unusual configuration to measure? (Going around corners)
- 3 Is this a single or double rail application? (The height to protect is the key factor)
- 4 Placing protection equipment a minimum of 12" in front of what you're protecting is required to achieve proper installation.

Part	A	B	C	D	E	F	G	H	I	J	K	L	M
	Base to Base	Rail Length	Rail Height	Base Length/Width	Visible Collar Length	Corner Collar Visible Width	Length of 2 Collared Rails	Height of Addl. Stacked Rails	Width of 2 Corner Collared Rails	Length of 2 Corner Collared BAR	Dist. of Holes on Base	Dist. of Holes Base to Base	Height of Rail w/Leg Extensions
BR-4	34"	48"	20"	10"	1"	10"	49" + Length of Additional Rail	32"	58"	10" + Length of Additional Rail	8"	16"	32"
BR-6	58"	72"	20"	10"	1"	10"	73" + Length of Additional Rail	32"	82"	10" + Length of Additional Rail	8"	40"	32"
BR-8	82"	96"	20"	10"	1"	10"	97" + Length of Additional Rail	32"	106"	10" + Length of Additional Rail	8"	64"	32"
BR-10	106"	120"	20"	10"	1"	10"	121" + Length of Additional Rail	32"	130"	10" + Length of Additional Rail	8"	88"	32"

Build-A-Rail Equipment Specification

Once you have measured the overall length of the area to be protected, you must divide length of area by length of rails. It is recommended to use as many of the longest rails evenly as possible and still protect the designated area. The reason for using the longest rail possible in even numbers is both for esthetic and economic considerations.

The longer the rail, the more coverage you receive while using fewer bases, which in turn gives you maximum protection for the most economical price. Standard rails are 4' to 10' long in 2' increments. Components are sold individually.